

## **CHAPTER 1 – Introduction to Machinery Principles**

### Summary:

1. Basic concept of electrical machines fundamentals:
  - Rotational component measurements
    - Angular Velocity, Acceleration
    - Torque, Work, Power
    - Newton's Law of Rotation
  - Magnetic Field study
    - Production of a Magnetic Field
    - Magnetic Circuits
2. Magnetic Behaviour of Ferromagnetic Materials
3. How magnetic field can affect its surroundings:
  - Faraday's Law – Induced Voltage from a Time-Changing Magnetic Field.
  - Production of Induced Force on a Wire.
  - Induced Voltage on a Conductor moving in a Magnetic Field
4. Linear DC Machines

## Introduction

1. Electric Machines → mechanical energy to electric energy or vice versa  
Mechanical energy → Electric energy : GENERATOR  
Electric energy → mechanical energy : MOTOR
2. Almost all practical motors and generators convert energy from one form to another through the action of a **magnetic field**.
3. Only machines using magnetic fields to perform such conversions will be considered in this course.
4. When we talk about machines, another related device is the transformer. A transformer is a device that converts ac electric energy at one voltage level to ac electric energy at another voltage level.
5. Transformers are usually studied together with generators and motors because they operate on the same principle, the difference is just in **the action of a magnetic field** to accomplish the change in voltage level.
6. Why are electric motors and generators so common?
  - electric power is a clean and efficient energy source that is very easy to transmit over long distances and easy to control.
  - Does not require constant ventilation and fuel (compare to internal-combustion engine), free from pollutant associated with combustion

### 1. Basic concept of electrical machines fundamentals

#### 1.1 Rotational Motion, Newton's Law and Power Relationship

Almost all electric machines **rotate about an axis**, called the shaft of the machines. It is important to have a basic understanding of rotational motion.

**Angular position,  $\theta$**  - is the angle at which it is oriented, measured from some arbitrary reference point. Its measurement units are in radians (rad) or in degrees. It is similar to the linear concept of distance along a line.

Conventional notation: +ve value for anticlockwise rotation  
-ve value for clockwise rotation

**Angular Velocity,  $\omega$**  - Defined as the velocity at which the measured point is moving. Similar to the concept of standard velocity where:

$$v = \frac{dr}{dt}$$

where:

- r – distance traverse by the body
- t – time taken to travel the distance r

For a rotating body, angular velocity is formulated as:

$$\omega = \frac{d\theta}{dt} \text{ (rad/s)}$$

where:

- $\theta$  - Angular position/ angular distance traversed by the rotating body
- t – time taken for the rotating body to traverse the specified distance,  $\theta$ .

**Angular acceleration,  $\alpha$**  - is defined as the rate of change in angular velocity with respect to time. Its formulation is as shown:

$$\alpha = \frac{d\omega}{dt} \text{ (rad/s}^2\text{)}$$

**Torque,  $\tau$**

1. In linear motion, a force applied to an object causes its velocity to change. In the absence of a net force on the object, its velocity is constant. The greater the force applied to the object, the more rapidly its velocity changes.
2. Similarly in the concept of rotation, when an object is rotating, its angular velocity is constant unless a torque is present on it. Greater the torque, more rapid the angular velocity changes.
3. Torque is known as a rotational force applied to a rotating body giving angular acceleration, a.k.a. 'twisting force'.
4. Definition of Torque: (Nm)

*'Product of force applied to the object and the smallest distance between the line of action of the force and the object's axis of rotation'*

$$\begin{aligned} \therefore \tau &= \text{Force} \times \text{perpendicular distance} \\ &= F \times r \sin \theta \end{aligned}$$

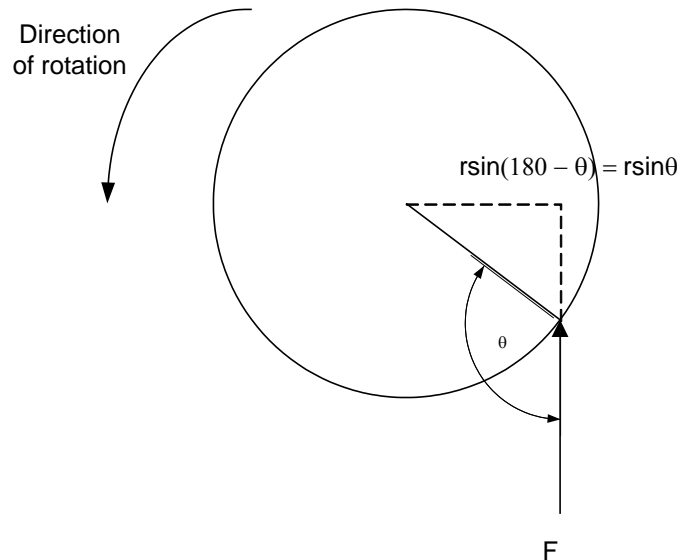

**Work, W** – is defined as the application of Force through a distance. Therefore, work may be defined as:

$$W = \int F dr$$

Assuming that the direction of F is collinear (in the same direction) with the direction of motion and constant in magnitude, hence,

$$W = Fr$$

Applying the same concept for rotating bodies,

$$W = \int \tau d\theta$$

Assuming that  $\tau$  is constant,

$$W = \tau\theta \text{ (Joules)}$$

**Power, P** – is defined as rate of doing work. Hence,

$$P = \frac{dW}{dt} \text{ (watts)}$$

Applying this for rotating bodies,

$$\begin{aligned} P &= \frac{d}{dt}(\tau\theta) \\ &= \tau \frac{d\theta}{dt} \\ &= \tau\omega \end{aligned}$$

This equation can describe the mechanical power on the shaft of a motor or generator.

### **Newton's Law of Rotation**

Newton's law for objects moving in a straight line gives a relationship between the force applied to the object and the acceleration experience by the object as the result of force applied to it. In general,

$$F = ma$$

where:

- F – Force applied
- m – mass of object
- a – resultant acceleration of object

Applying these concept for rotating bodies,

$$\tau = J\alpha \text{ (Nm)}$$

where:

- $\tau$  - Torque
- J – moment of inertia
- $\alpha$  - angular acceleration

## **1.2 The Magnetic Field**

Magnetic fields are the **fundamental mechanism by which energy is converted** from one form to another in motors, generators and transformers.

First, we are going to look at the basic principle – **A current-carrying wire produces a magnetic field in the area around it.**

### **Production of a Magnetic Field**

1. **Ampere's Law** – the basic law governing the production of a magnetic field by a current:

$$\oint H dl = I_{net}$$

where **H** is the magnetic field intensity produced by the current  $I_{net}$  and  $dl$  is a differential element of length along the path of integration. H is measured in Ampere-turns per meter.

2. Consider a current carrying conductor is wrapped around a ferromagnetic core;

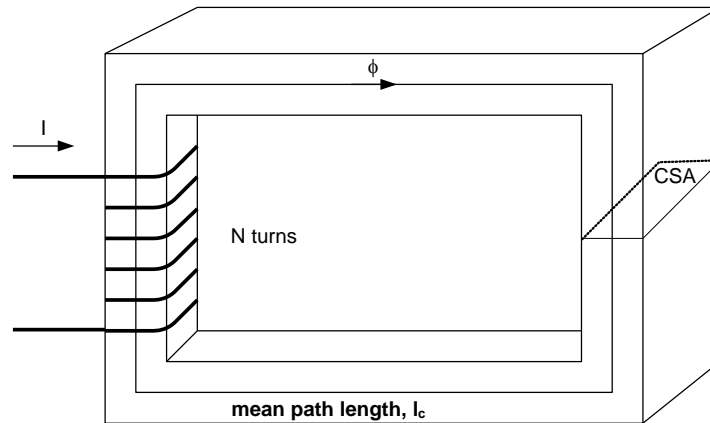

3. Applying Ampere's law, the total amount of magnetic field induced will be proportional to the amount of current flowing through the conductor wound with N turns around the ferromagnetic material as shown. Since the core is made of ferromagnetic material, it is assumed that a majority of the magnetic field will be confined to the core.
4. The path of integration in Ampere's law is the mean path length of the core,  $l_c$ . The current passing within the path of integration  $I_{net}$  is then  $Ni$ , since the coil of wires cuts the path of integration N times while carrying the current  $i$ . Hence Ampere's Law becomes,

$$Hl_c = Ni$$

$$\therefore H = \frac{Ni}{l_c}$$

5. In this sense, H (Ampere turns per metre) is known as the effort required to induce a magnetic field. The strength of the magnetic field flux produced in the core also depends on the material of the core. Thus,

$$B = \mu H$$

B = magnetic flux density (webers per square meter, Tesla (T))

$\mu$  = magnetic permeability of material (Henry's per meter)

H = magnetic field intensity (ampere-turns per meter)

6. The constant  $\mu$  may be further expanded to include *relative permeability* which can be defined as below:

$$\mu_r = \frac{\mu}{\mu_o}$$

where:  $\mu_o$  – permeability of free space (a.k.a. air)

7. Hence the permeability value is a combination of the relative permeability and the permeability of free space. The value of relative permeability is dependent upon the type of material used. The higher the amount permeability, the higher the amount of flux induced in the core. Relative permeability is a convenient way to compare the magnetizability of materials.
8. Also, because the permeability of iron is so much higher than that of air, the majority of the flux in an iron core remains inside the core instead of travelling through the surrounding air, which has lower permeability. The small leakage flux that does leave the iron core is important in determining the flux linkages between coils and the self-inductances of coils in transformers and motors.

9. In a core such as in the figure,

$$B = \mu H = \frac{\mu Ni}{l_c}$$

Now, to measure the total flux flowing in the ferromagnetic core, consideration has to be made in terms of its cross sectional area (CSA). Therefore,

$$\phi = \int_A B dA$$

Where: A – cross sectional area throughout the core

Assuming that the flux density in the ferromagnetic core is constant throughout hence constant A, the equation simplifies to be:

$$\phi = BA$$

Taking into account past derivation of B,

$$\phi = \frac{\mu NiA}{l_c}$$

## 2. Magnetics Circuits

The flow of magnetic flux induced in the ferromagnetic core can be made analogous to an electrical circuit hence the name magnetic circuit.

The analogy is as follows:

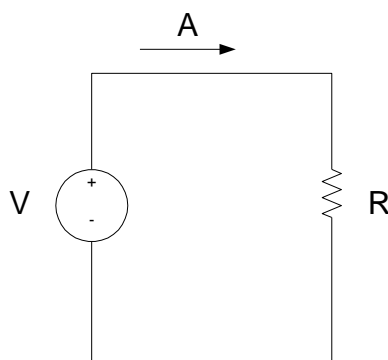

*Electric Circuit Analogy*

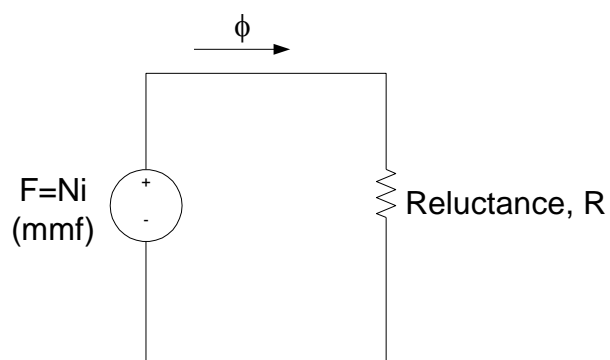

*Magnetic Circuit Analogy*

- Referring to the magnetic circuit analogy, F is denoted as **magnetomotive force** (mmf) which is similar to Electromotive force in an electrical circuit (emf). Therefore, we can safely say that F is the prime mover or force which pushes magnetic flux around a ferromagnetic core at a value of Ni (refer to ampere's law). Hence F is measured in ampere turns. Hence the magnetic circuit equivalent equation is as shown:

$$F = \phi R \quad (\text{similar to } V=IR)$$

- The polarity of the mmf will determine the direction of flux. To easily determine the direction of flux, the 'right hand curl' rule is utilised:
  - The direction of the curled fingers determines the current flow.
  - The resulting thumb direction will show the magnetic flux flow.

3. The element of R in the magnetic circuit analogy is similar in concept to the electrical resistance. **It is basically the measure of material resistance to the flow of magnetic flux.** Reluctance in this analogy obeys the rule of electrical resistance (Series and Parallel Rules). Reluctance is measured in Ampere-turns per weber.

Series Reluctance,

$$R_{eq} = R_1 + R_2 + R_3 + \dots$$

Parallel Reluctance,

$$\frac{1}{R_{eq}} = \frac{1}{R_1} + \frac{1}{R_2} + \frac{1}{R_3} + \dots$$

4. The inverse of electrical resistance is conductance which is a measure of conductivity of a material. Hence the inverse of reluctance is known as **permeance, P** where it represents the degree at which the material permits the flow of magnetic flux.

$$P = \frac{1}{R}$$

$$\therefore \text{since } \phi = \frac{F}{R}$$

$$\therefore \phi = FP$$

Also,

$$\begin{aligned} \phi &= \frac{\mu NiA}{l_c} \\ &= Ni \frac{\mu A}{l_c} \\ &= F \frac{\mu A}{l_c} \\ \therefore P &= \frac{\mu A}{l_c}, R = \frac{l_c}{\mu A} \end{aligned}$$

5. By using the magnetic circuit approach, it simplifies calculations related to the magnetic field in a ferromagnetic material, however, this approach has inaccuracy embedded into it due to assumptions made in creating this approach (within 5% of the real answer). Possible reason of inaccuracy is due to:
- The magnetic circuit assumes that all flux are confined within the core, but in reality a small fraction of the flux escapes from the core into the surrounding low-permeability air, and this flux is called **leakage flux**.
  - The reluctance calculation assumes a certain mean path length and cross sectional area (csa) of the core. This is alright if the core is just one block of ferromagnetic material with no corners, for practical ferromagnetic cores which have **corners** due to its design, this assumption is not accurate.

- c) In ferromagnetic materials, the permeability varies with the amount of flux already in the material. The material permeability is not constant hence there is an existence of **non-linearity of permeability**.
- d) For ferromagnetic core which has air gaps, there are **fringing effects** that should be taken into account as shown:

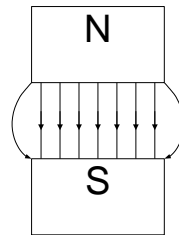

**Example 1.1**

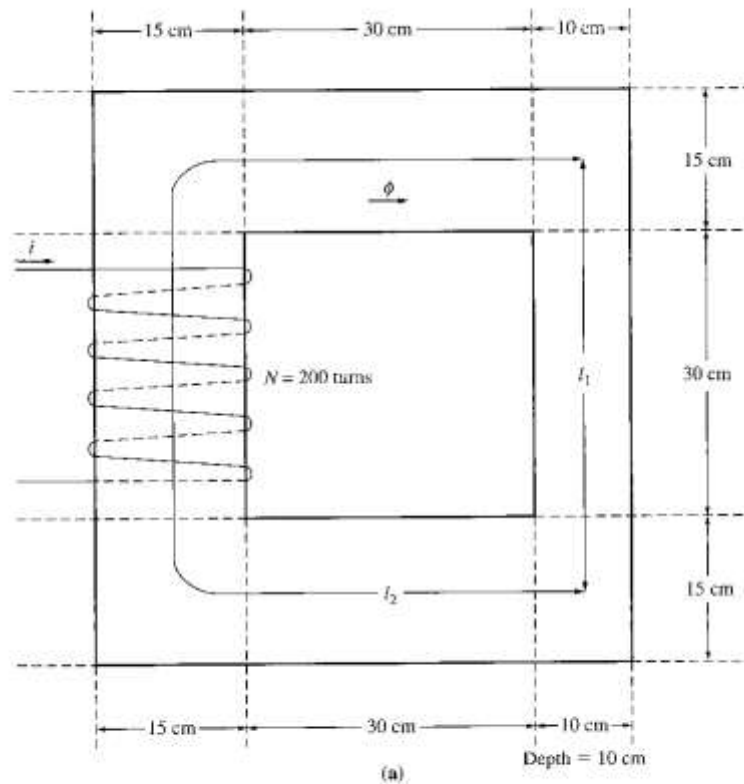

A ferromagnetic core is shown. Three sides of this core are of uniform width, while the fourth side is somewhat thinner. The depth of the core (into the page) is 10cm, and the other dimensions are shown in the figure. There is a 200 turn coil wrapped around the left side of the core. Assuming relative permeability  $\mu_r$  of 2500, **how much flux will be produced** by a 1A input current?

*Solution:*

3 sides of the core have the same csa, while the 4<sup>th</sup> side has a different area. Thus the core can be divided into 2 regions:

- (1) the single thinner side
- (2) the other 3 sides taken together

The magnetic circuit corresponding to this core:

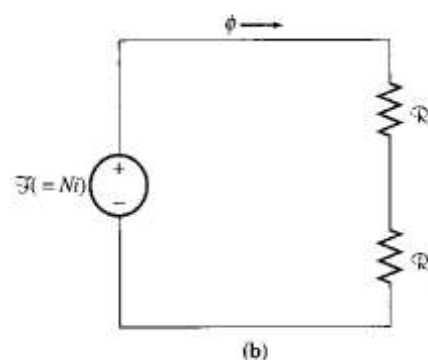

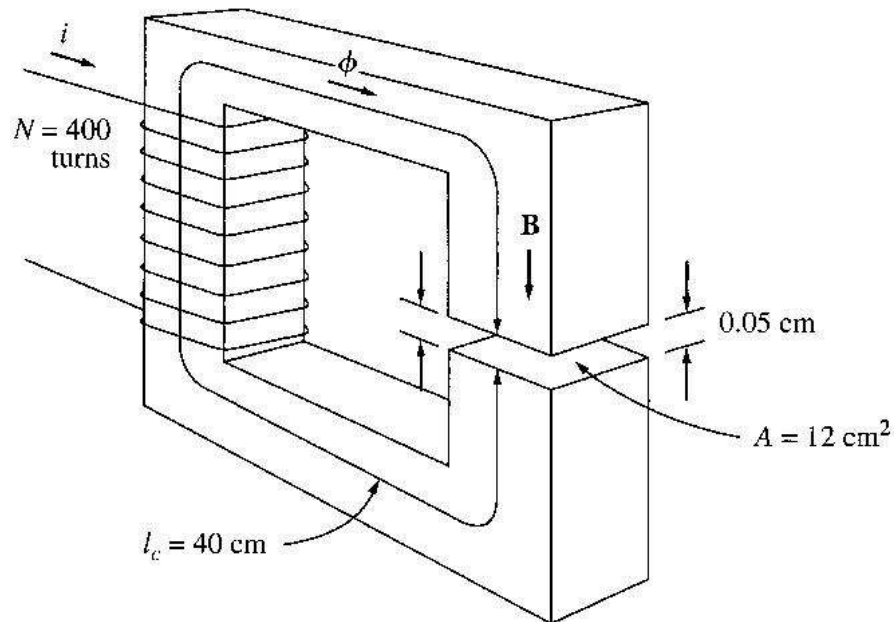

**Example 1.2**

(a)

Figure shows a ferromagnetic core whose mean path length is 40cm. There is a small gap of 0.05cm in the structure of the otherwise whole core. The csa of the core is  $12\text{cm}^2$ , the relative permeability of the core is 4000, and the coil of wire on the core has 400 turns. Assume that fringing in the air gap increases the effective csa of the gap by 5%. Given this information, find

- the **total reluctance** of the flux path (iron plus air gap)
- the **current** required to produce a flux density of 0.5T in the air gap.

*Solution:*

The magnetic circuit corresponding to this core is shown below:

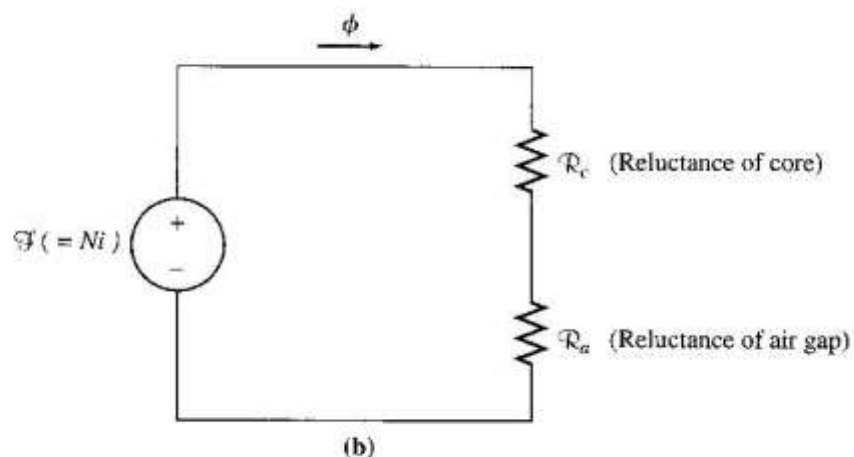

(b)

**Example 1.3**

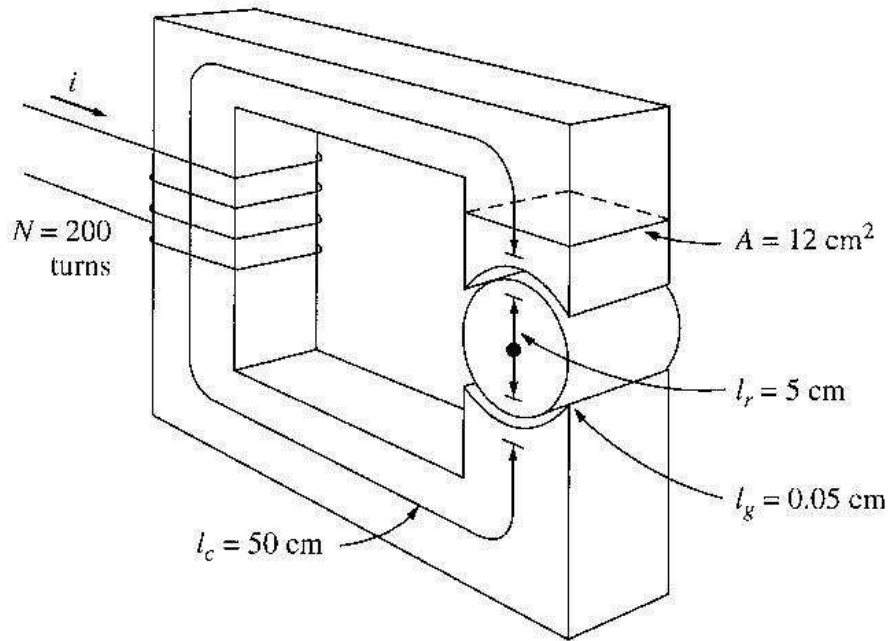
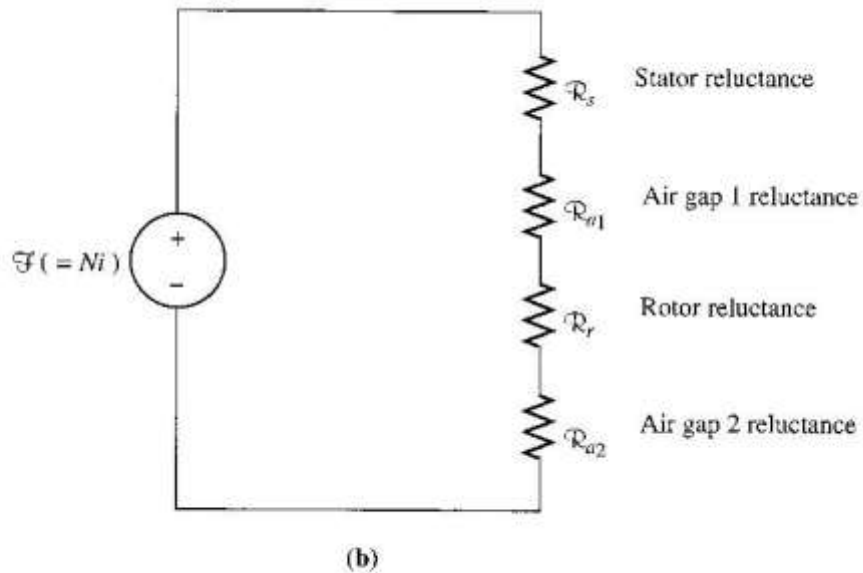

Figure shows a simplified rotor and stator for a dc motor. The mean path length of the stator is 50cm, and its csa is  $12\text{cm}^2$ . The mean path length of the rotor is 5 cm, and its csa also may be assumed to be  $12\text{cm}^2$ . Each air gap between the rotor and the stator is 0.05cm wide, and the csa of each air gap (including fringing) is  $14\text{cm}^2$ . The iron of the core has a relative permeability of 2000, and there are 200 turns of wire on the core. If the current in the wire is adjusted to be 1A, what will the **resulting flux density in the air gaps** be?

*Solution:*

To determine the flux density in the air gap, it is necessary to first calculate the mmf applied to the core and the total reluctance of the flux path. With this information, the total flux in the core can be found. Finally, knowing the csa of the air gaps enables the flux density to be calculated.

The magnetic cct corresponding to this machine is shown below.



## Magnetic Behaviour of Ferromagnetic Materials

1. Materials which are classified as non-magnetic all show a linear relationship between the flux density  $B$  and coil current  $I$ . In other words, they have constant permeability. Thus, for example, in free space, the permeability is constant. But in iron and other ferromagnetic materials it is not constant.
2. For magnetic materials, a much larger value of  $B$  is produced in these materials than in free space. Therefore, the permeability of magnetic materials is much higher than  $\mu_0$ . However, the permeability is not linear anymore but does depend on the current over a wide range.
3. Thus, the **permeability is the property of a medium that determines its magnetic characteristics**. In other words, the concept of magnetic permeability corresponds to the ability of the material to permit the flow of magnetic flux through it.
4. In electrical machines and electromechanical devices a somewhat linear relationship between  $B$  and  $I$  is desired, which is normally approached by limiting the current.
5. Look at the magnetization curve and B-H curve. Note: The curve corresponds to an increase of DC current flow through a coil wrapped around the ferromagnetic core (ref: Electrical Machinery Fundamentals 4<sup>th</sup> Ed. – Stephen J Chapman).

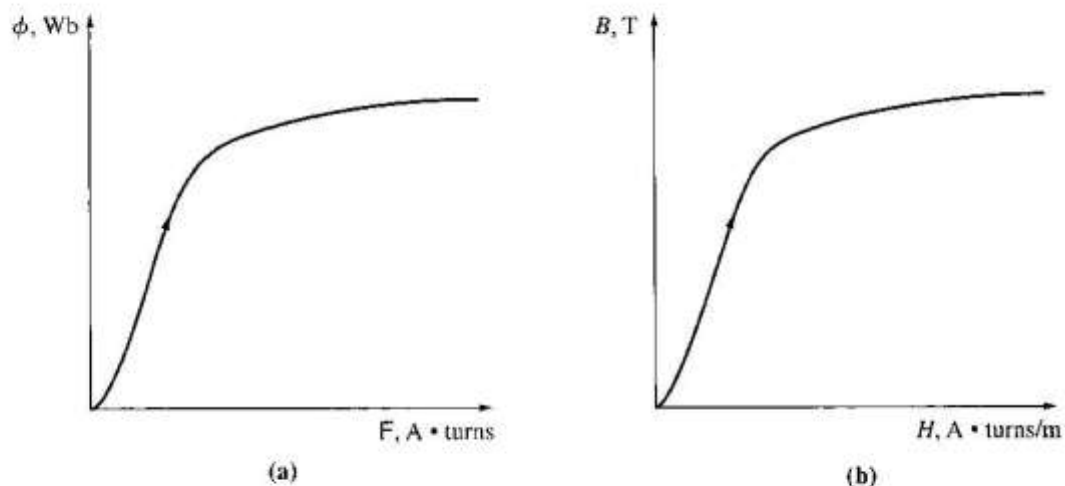

6. When the flux produced in the core is plotted versus the mmf producing it, the resulting plot looks like this (a). This plot is called a **saturation curve** or a **magnetization curve**. A small increase in the mmf produces a huge increase in the resulting flux. After a certain point, further increases in the mmf produce relatively smaller increases in the flux. Finally, there will be no change at all as you increase mmf further. The region in which the curve flattens out is called saturation region, and the core is said to be saturated. The region where the flux changes rapidly is called **the unsaturated region**. The transition region is called the 'knee' of the curve.
7. From equation  $H = Ni/l_c = F/l_c$  and  $\phi = BA$ , it can be seen that magnetizing intensity is directly proportional to mmf and magnetic flux density is directly proportional to flux for any given core.  $B = \mu H \rightarrow$  slope of curve is the permeability of the core at that magnetizing intensity. The curve (b) shows that the permeability is large and relatively constant in the unsaturated region and then gradually drops to a low value as the core become heavily saturated.
8. Advantage of using a ferromagnetic material for cores in electric machines and transformers is that one gets more flux for a given mmf than with air (free space).

9. If the resulting flux has to be proportional to the mmf, then the core must be operated in the unsaturated region.
10. Generators and motors depend on magnetic flux to produce voltage and torque, so they need as much flux as possible. So, they operate near the knee of the magnetization curve (flux not linearly related to the mmf). This non-linearity as a result gives peculiar behaviours to machines.
11. As magnetizing intensity  $H$  increased, the relative permeability first increases and then starts to drop off.

**Example 1.5**

A square magnetic core has a mean path length of 55cm and a csa of  $150\text{cm}^2$ . A 200 turn coil of wire is wrapped around one leg of the core. The core is made of a material having the magnetization curve shown below. Find:

- a) How much current is required to produce 0.012 Wb of flux in the core?
- b) What is the core's relative permeability at that current level?
- c) What is its reluctance?

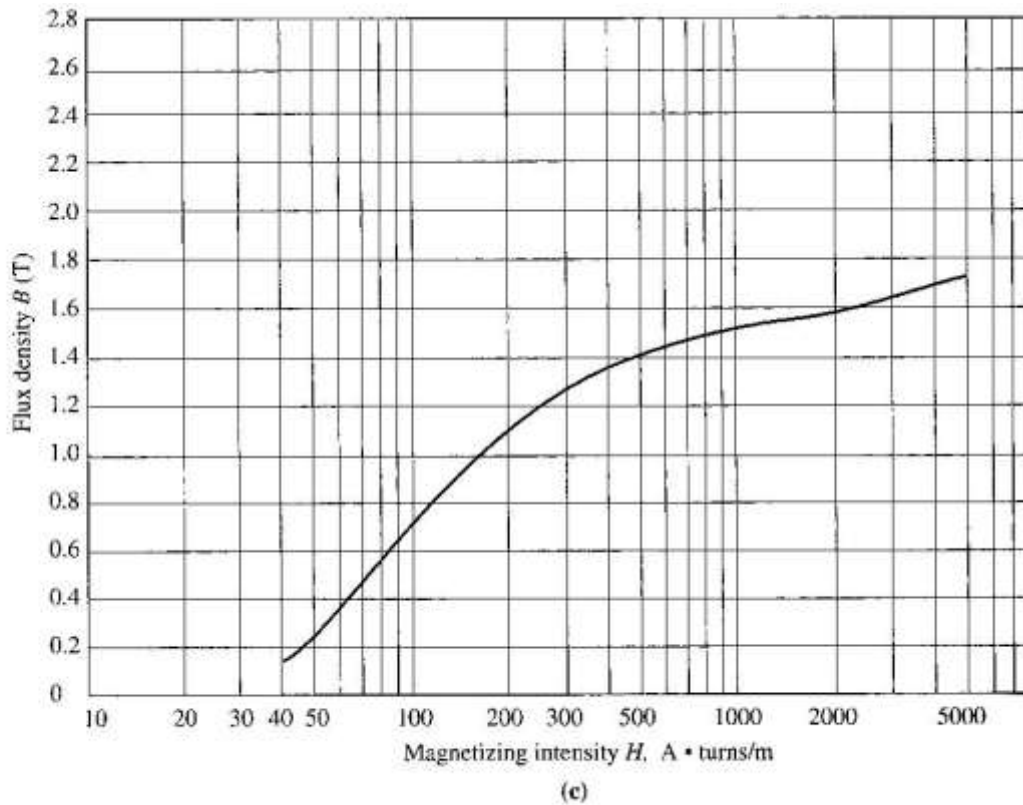

## Energy Losses in a Ferromagnetic Core

### I. Hysteresis Loss

1. Discussions made before concentrates on the application of a DC current through the coil. Now let's move the discussion into the application of AC current source at the coil. Using our understanding previously, we can predict that the curve would be as shown,

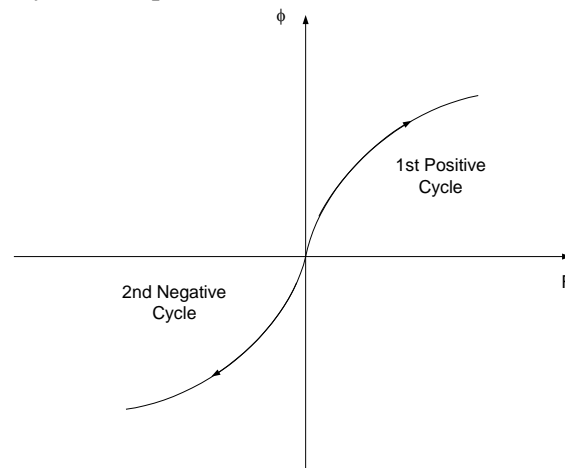

*Theoretical ac magnetic behaviour for flux in a ferromagnetic core.*

2. Unfortunately, the above assumption is only correct provided that the core is 'perfect' i.e. there are no residual flux present during the negative cycle of the ac current flow. A typical flux behaviour (or known as hysteresis loop) in a ferromagnetic core is as shown in the next page.

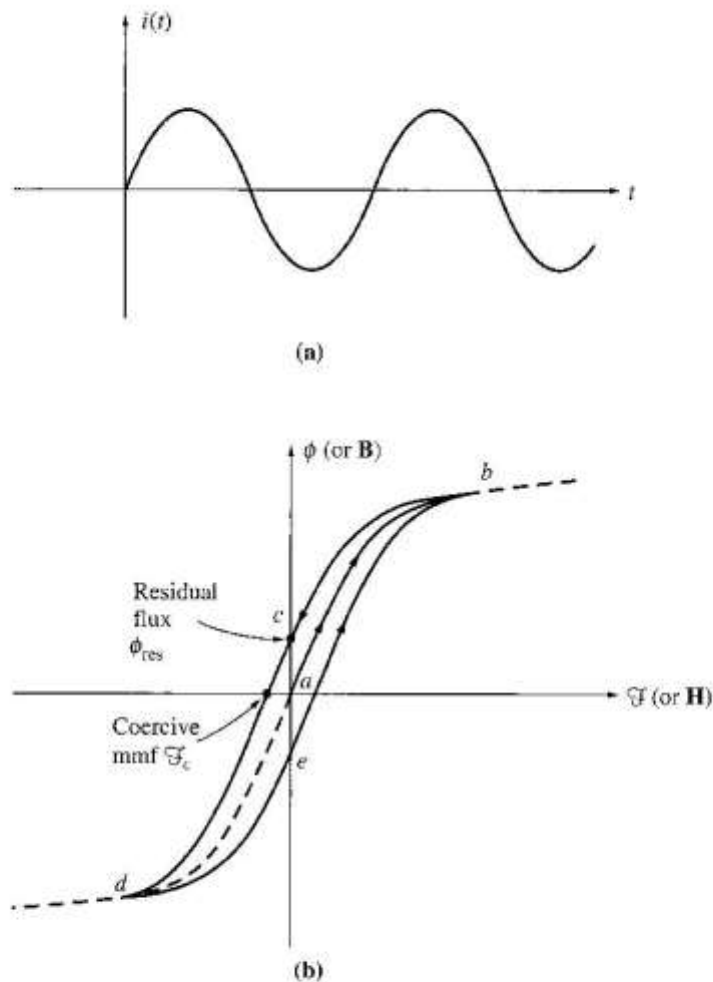

Typical Hysteresis loop when ac current is applied.

### 3. Explanation of Hysteresis Loop

- Apply AC current. Assume flux in the core is initially zero.
- As current increases, the flux traces the path  $ab$ . (saturation curve)
- When the current decreases, the flux traces out a different path from the one when the current increases.
- When current decreases, the flux traces out path  $bcd$ .
- When the current increases again, it traces out path  $deb$ .
- NOTE: the amount of flux present in the core depends not only on the amount of current applied to the windings of the core, but also on the previous history of the flux in the core.
- HYSTeresis is the dependence on the preceding flux history and the resulting failure to retrace flux paths.
- When a large mmf is first applied to the core and then removed, the flux path in the core will be  $abc$ .
- When mmf is removed, the flux does not go to zero – **residual flux**. This is how permanent magnets are produced.
- To force the flux to zero, an amount of mmf known as **coercive mmf** must be applied in the opposite direction.

4. Why does hysteresis occur?

- ❖ To understand hysteresis in a ferromagnetic core, we have to look into the behaviour of its atomic structure before, during and after the presence of a magnetic field.
- ❖ The atoms of iron and similar metals (cobalt, nickel, and some of their alloys) tend to have their magnetic fields closely aligned with each other. Within the metal, there is an existence of small regions known as **domains** where in each domain there is a presence of a small magnetic field which randomly aligned through the metal structure.

This as shown below:

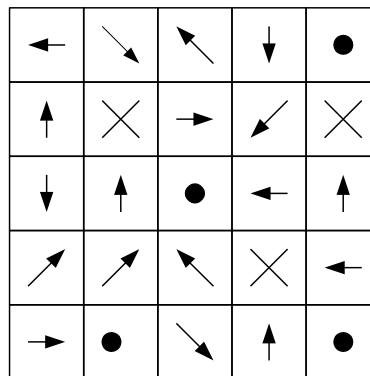

*An example of a magnetic domain orientation in a metal structure before the presence of a magnetic field.*

- ❖ Magnetic field direction in each domain is random as such that the net magnetic field is zero.
- ❖ When mmf is applied to the core, each magnetic field will align with respect to the direction of the magnetic field. That explains the exponential increase of magnetic flux during the early stage of magnetisation. As more and more domain are aligned to the magnetic field, the total magnetic flux will maintain at a constant level hence as shown in the magnetisation curve (saturation).
- ❖ When mmf is removed, the magnetic field in each domain **will try** to revert to its random state.
- ❖ However, **not all** magnetic field domain's would revert to its random state hence it remained in its previous magnetic field position. This is due to the lack of energy required to disturb the magnetic field alignment.
- ❖ Hence the material will retain some of its magnetic properties (permanent magnet) up until an external energy is applied to the material. Examples of external energy may be in the form of heat or large mechanical shock. That is why a permanent magnet can lose its magnetism if it is dropped, hit with a hammer or heated.
- ❖ Therefore, in an ac current situation, to realign the magnetic field in each domain during the opposite cycle would require extra mmf (also known as coercive mmf).
- ❖ This extra energy requirement is known as **hysteresis loss**.
- ❖ The larger the material, the more energy is required hence the higher the hysteresis loss.
- ❖ Area enclosed in the hysteresis loop formed by applying an ac current to the core is directly proportional to the energy lost in a given ac cycle.

## II. Eddy Current Loss

1. A time-changing flux induces voltage within a ferromagnetic core.
2. These voltages cause swirls of current to flow within the core – eddy currents.
3. Energy is dissipated (in the form of heat) because these eddy currents are flowing in a resistive material (iron)
4. The amount of energy lost to eddy currents is proportional to the **size of the paths** they follow within the core.
5. To reduce energy loss, ferromagnetic core should be broken up into small strips, or laminations, and build the core up out of these strips. An insulating oxide or resin is used between the strips, so that the current paths for eddy currents are limited to small areas.

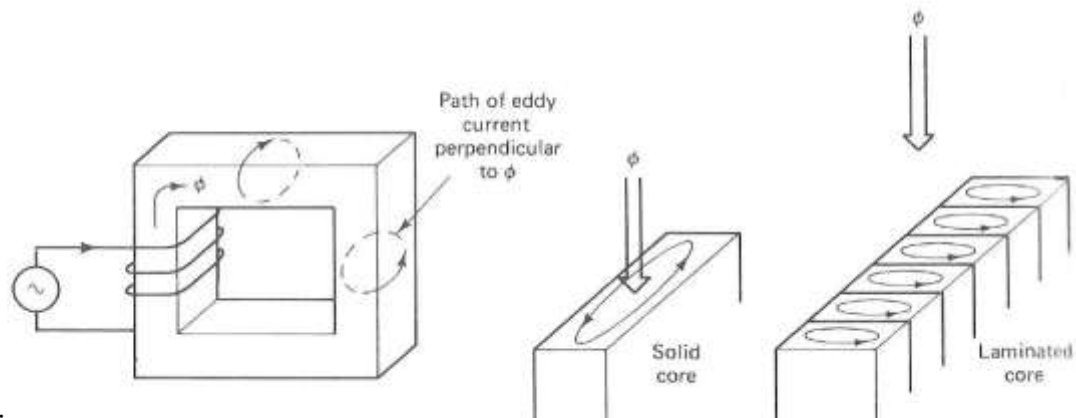

Conclusion:

Core loss is extremely important in practice, since it greatly affects operating temperatures, efficiencies, and ratings of magnetic devices.

### 3. How Magnetic Field can affect its surroundings

#### 3.1 FARADAY'S LAW – Induced Voltage from a Time-Changing Magnetic Field

Before, we looked at the production of a magnetic field and on its properties. Now, we will look at the various ways in which an existing magnetic field can affect its surroundings.

1. Faraday's Law:

*'If a flux passes through a turn of a coil of wire, voltage will be induced in the turn of the wire that is directly proportional to the rate of change in the flux with respect of time'*

$$e_{ind} = -\frac{d\phi}{dt}$$

If there is N number of turns in the coil with the same amount of flux flowing through it, hence:

$$e_{ind} = -N \frac{d\phi}{dt}$$

where: N – number of turns of wire in coil.

Note the negative sign at the equation above which is in accordance to **Lenz' Law** which states:

*'The direction of the build-up voltage in the coil is as such that if the coils were short circuited, it would produce current that would cause a flux opposing the original flux change.'*



Examine the figure below:

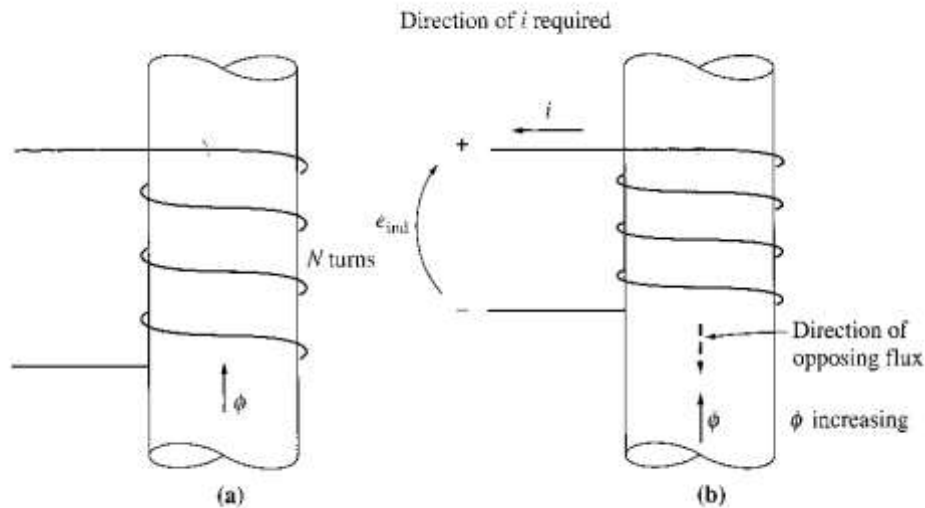

- If the flux shown is increasing in strength, then the voltage built up in the coil will **tend to establish a flux that will oppose the increase.**
  - A current flowing as shown in the figure would produce a flux opposing the increase.
  - So, the voltage on the coil must be built up with the polarity required to drive the current through the external circuit. So,  $-e_{ind}$
  - NOTE: In Chapman, the minus sign is often left out because the polarity of the resulting voltage can be determined from physical considerations.
2. Equation  $e_{ind} = -d\phi/dt$  assumes that exactly the same flux is present in each turn of the coil. This is not true, since there is leakage flux. This equation will give valid answer if the windings are tightly coupled, so that the vast majority of the flux passing thru one turn of the coil does indeed pass through all of them.
  3. Now consider the induced voltage in the  $i$ th turn of the coil,

$$e_i = \frac{d\phi_i}{dt}$$

Since there is  $N$  number of turns,

$$\begin{aligned} e_{ind} &= \sum_{i=1}^N e_i \\ &= \sum_{i=1}^N \frac{d\phi_i}{dt} \\ &= \frac{d}{dt} \left( \sum_{i=1}^N \phi_i \right) \end{aligned}$$

The equation above may be rewritten into,

$$e_{ind} = \frac{d\lambda}{dt}$$

where  $\lambda$  (flux linkage) is defined as:

$$\lambda = \sum_{i=1}^N \phi_i \quad (\text{weber-turns})$$

- Faraday's law is the fundamental property of magnetic fields involved in transformer operation.
- Lenz's Law in transformers is used to predict the polarity of the voltages induced in transformer windings.

### 3.2 Production of Induced Force on a Wire.

- A current carrying conductor present in a uniform magnetic field of flux density  $B$ , would produce a force to the conductor/wire. Dependent upon the direction of the surrounding magnetic field, the force induced is given by:

$$F = i(l \times B)$$

where:

$i$  – represents the current flow in the conductor

$l$  – length of wire, with direction of  $l$  defined to be in the direction of current flow

$B$  – magnetic field density

- The direction of the force is given by the right-hand rule. Direction of the force depends on the direction of current flow and the direction of the surrounding magnetic field. A rule of thumb to determine the direction can be found using the right-hand rule as shown below:

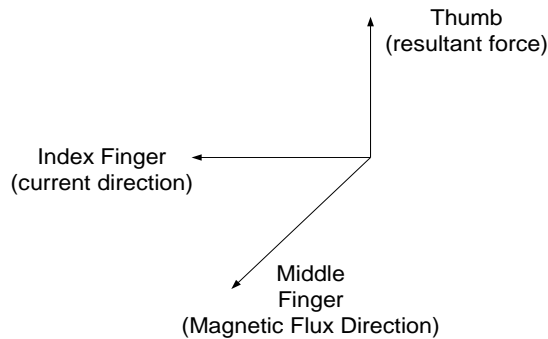

**Right Hand rule**

- The induced force formula shown earlier is true if the current carrying conductor is perpendicular to the direction of the magnetic field. If the current carrying conductor is position at an angle to the magnetic field, the formula is modified to be as follows:

$$F = ilB \sin \theta$$

Where:  $\theta$  - angle between the conductor and the direction of the magnetic field.

- In summary, this phenomenon is the basis of an **electric motor** where torque or rotational force of the motor is the effect of the stator field current and the magnetic field of the rotor.

#### Example 1.7

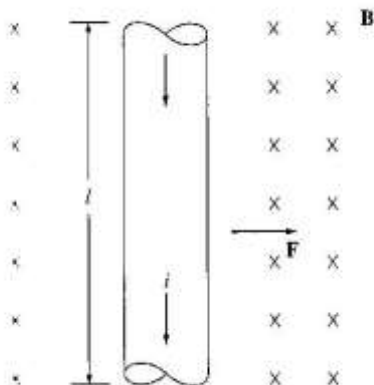

The figure shows a wire carrying a current in the presence of a magnetic field. The magnetic flux density is 0.25T, directed into the page. If the wire is 1m long and carries 0.5A of current in the direction from the top of the page to the bottom, what are the magnitude and direction of the force induced on the wire?

### 3.3 Induced Voltage on a Conductor Moving in a Magnetic Field

1. If a conductor moves or 'cuts' through a magnetic field, voltage will be induced between the terminals of the conductor at which the magnitude of the induced voltage is dependent upon the velocity of the wire assuming that the magnetic field is constant. This can be summarised in terms of formulation as shown:

$$e_{ind} = (v \times B) l$$

where:

- v – velocity of the wire
- B – magnetic field density
- l – length of the wire in the magnetic field

2. Note: The value of l (length) is dependent upon the angle at which the wire cuts through the magnetic field. Hence a more complete formula will be as follows:

$$e_{ind} = (v \times B) l \cos\theta$$

where:

- $\theta$  - angle between the conductor and the direction of ( $v \times B$ )

3. The induction of voltages in a wire moving in a magnetic field is fundamental to the operation of all types of **generators**.

#### Example 1.8

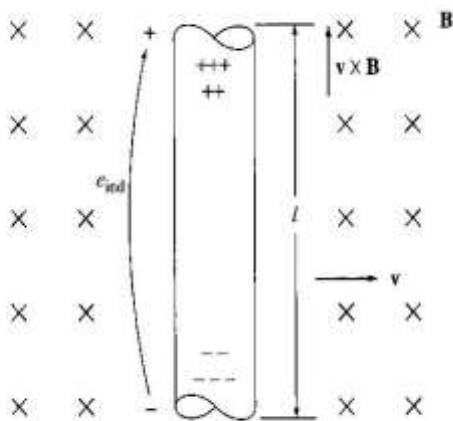

The figure shows a conductor moving with a velocity of 5m/s to the right in the presence of a magnetic field. The flux density is 0.5T into the page, and the wire is 1m length, oriented as shown. What are the magnitude and polarity of the resulting induced voltage?

#### Example 1.9

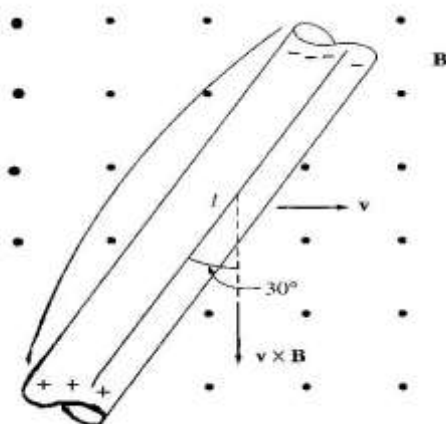
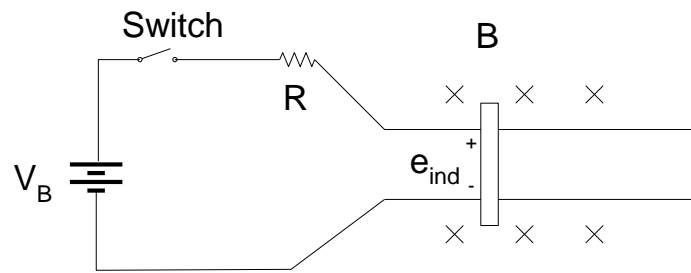

Figure shows a conductor moving with a velocity of 10m/s to the right in a magnetic field. The flux density is 0.5T, out of the page, and the wire is 1m in length. What are the magnitude and polarity of the resulting induced voltage?

#### 4. The Linear DC Machine

Linear DC machine is the simplest form of DC machine which is easy to understand and it operates according to the same principles and exhibits the same behaviour as motors and generators. Consider the following:



Equations needed to understand linear DC machines are as follows:

##### **Production of Force on a current carrying conductor**

$$F = i(l \times B)$$

##### **Voltage induced on a current carrying conductor moving in a magnetic field**

$$e_{ind} = (v \times B) l$$

##### **Kirchoff's voltage law**

$$V_B - iR - e_{ind} = 0$$

$$\therefore V_B = e_{ind} + iR = 0$$

##### **Newton's Law for motion**

$$F_{net} = ma$$

## Starting the Linear DC Machine

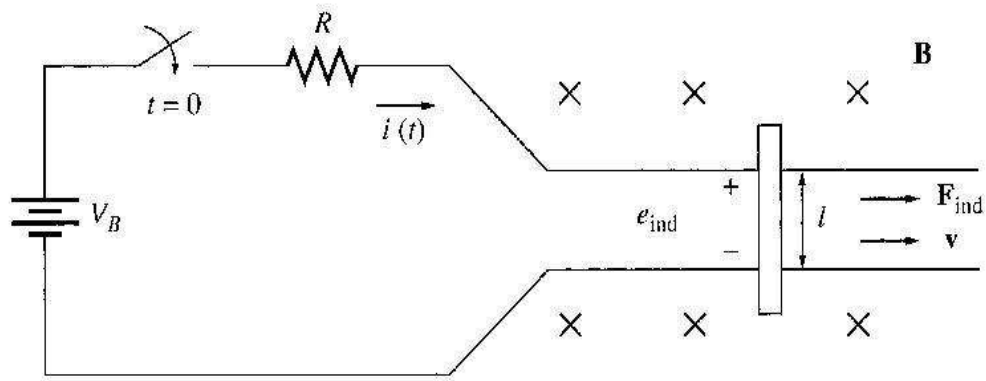

1. To start the machine, the switch is closed.
2. Current will flow in the circuit and the equation can be derived from Kirchoff's law:

$$\text{Since, } V_B = iR + e_{ind}$$

$$\therefore i = \frac{V_B - e_{ind}}{R}$$

At this moment, the induced voltage is 0 due to no movement of the wire (the bar is at rest).

3. As the current flows down through the bar, a force will be induced on the bar. (Section 1.6 a current flowing through a wire in the presence of a magnetic field induces a force in the wire).

$$F = i (l \times B)$$

$$= ilB \sin 90$$

$$= ilB$$

Direction of movement: Right

4. When the bar starts to move, its velocity will increase, and a voltage appears across the bar.

$$e_{ind} = (v \times B)l$$

$$= vBl \sin 90^\circ$$

$$= ilB$$

Direction of induced potential: positive upwards

5. Due to the presence of motion and induced potential ( $e_{ind}$ ), the current flowing in the bar will reduce (according to Kirchoff's voltage law). The result of this action is that eventually the bar will reach a constant steady-state speed where the net force on the bar is zero. This occurs when  $e_{ind}$  has risen all the way up to equal  $V_B$ . This is given by:

$$V_B = e_{ind} = v_{steady\ state} Bl$$

$$\therefore v_{steady\ state} = \frac{V_B}{Bl}$$

6. The above equation is true assuming that  $R$  is very small. The bar will continue to move along at this no-load speed forever unless some external force disturbs it. Summarization of the starting of linear DC machine is sketched in the figure below:

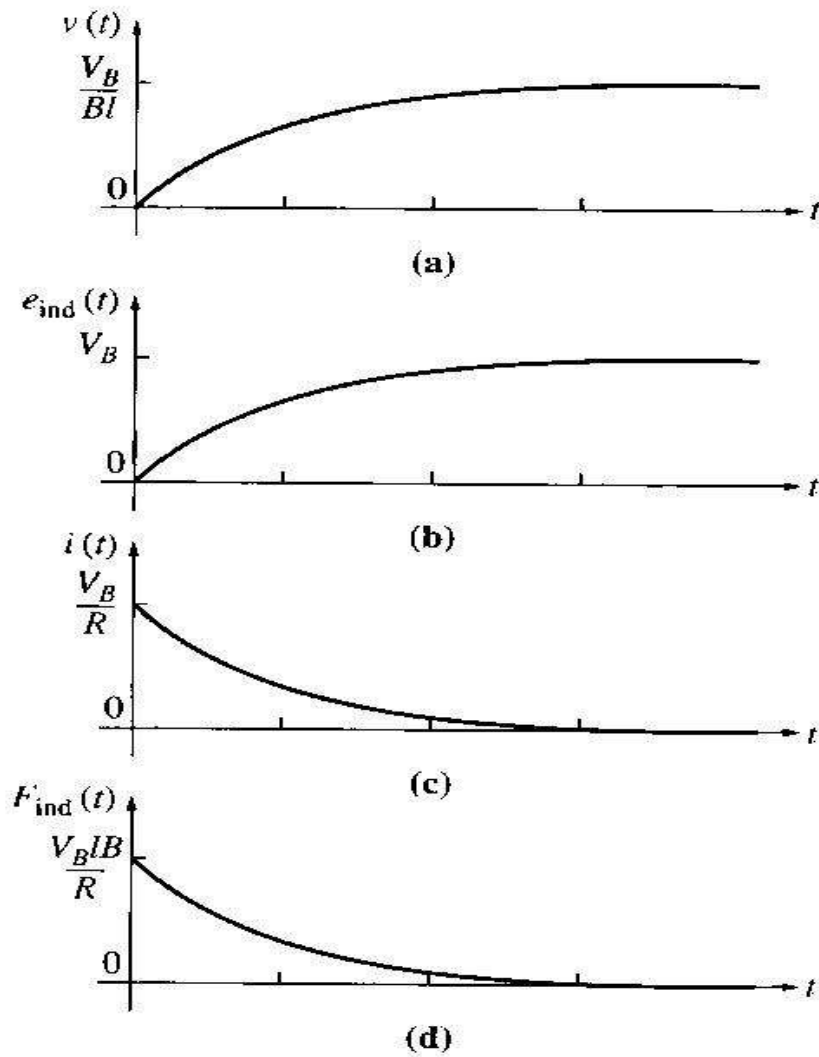

The Linear DC Machine as a Motor

1. Assume the linear machine is initially running at the no-load steady state condition (as before).
2. What happen when an external load is applied? See figure below:

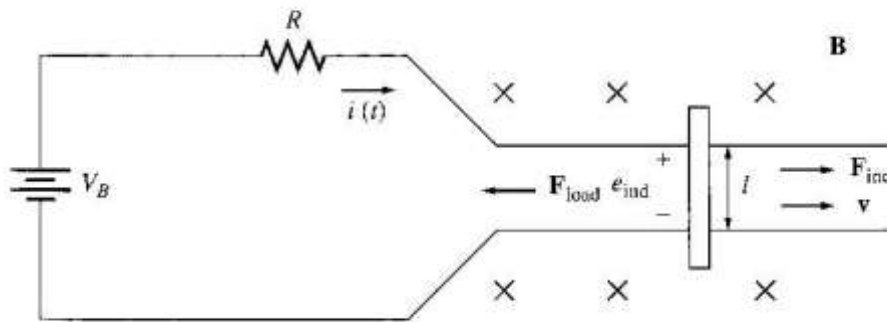

3. A force  $F_{load}$  is applied to the bar opposing the direction of motion. Since the bar was initially at steady state, application of the force  $F_{load}$  will result in a net force on the bar in the direction opposite the direction of motion.

$$F_{net} = F_{load} - F_{ind}$$

4. Thus, the bar will slow down (the resulting acceleration  $a = F_{net}/m$  is negative). As soon as that happen, the induced voltage on the bar drops ( $e_{ind} = v \downarrow Bl$ ).
5. When the induced voltage drops, the current flow in the bar will rise:

$$i \uparrow = \frac{V_B - e_{ind} \downarrow}{R}$$

6. Thus, the induced force will rise too. ( $F_{ind} \uparrow = i \uparrow lB$ )
7. Final result  $\rightarrow$  the induced force will rise until it is equal and opposite to the load force, and the bar again travels in steady state condition, but at a lower speed. See graphs below:

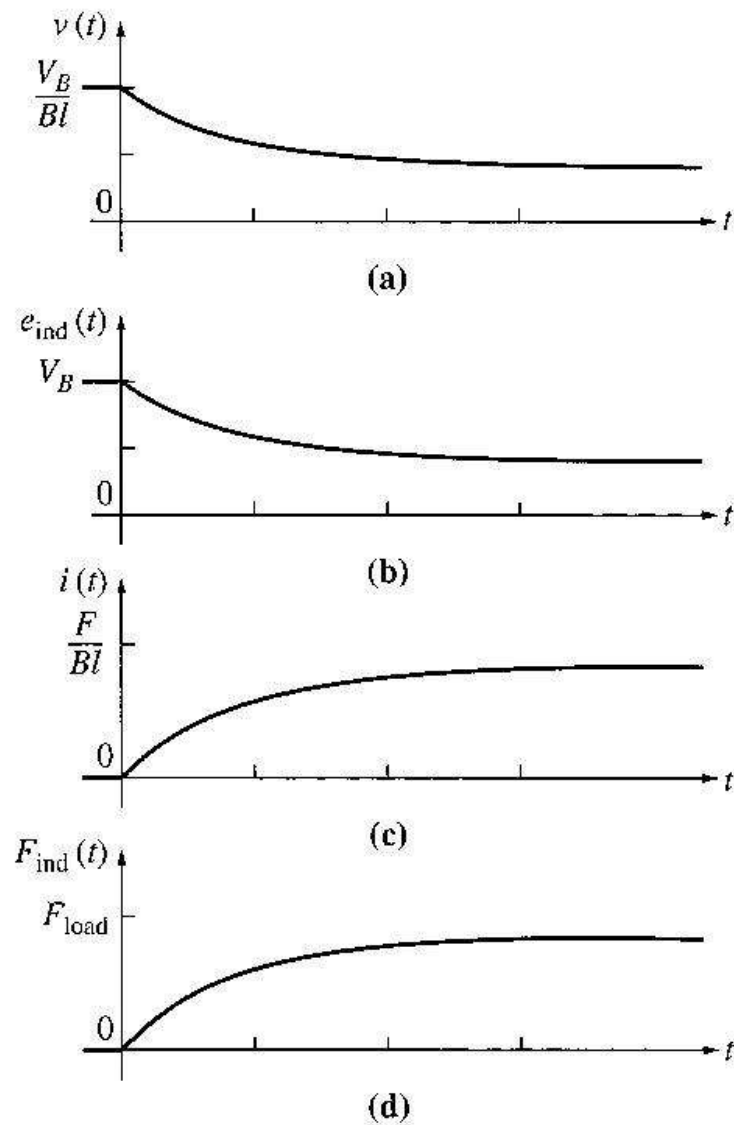

8. Now, there is an induced force in the direction of motion and power is being converted from **electrical to mechanical form** to keep the bar moving.
9. The power converted is  $P_{conv} = e_{ind} I = F_{ind} v \rightarrow$  An amount of electric power equal to  $e_{ind} i$  is consumed and is replaced by the mechanical power  $F_{ind} v \rightarrow$  **MOTOR**
10. The power converted in a real rotating motor is:  $P_{conv} = \tau_{ind} \omega$



### The Linear DC Machine as a Generator

1. Assume the linear machine is operating under no-load steady-state condition. A force in the direction of motion is applied.

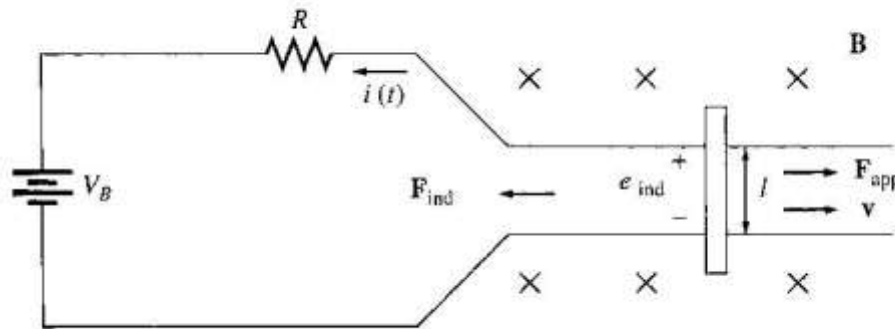

2. The applied force will cause the bar to accelerate in the direction of motion, and the velocity  $v$  will increase.
3. When the velocity increase,  $e_{ind} = v \uparrow Bl$  will increase and will be larger than  $V_B$ .
4. When  $e_{ind} > V_B$  the current reverses direction.
5. Since the current now flows up through the bar, it induces a force in the bar ( $F_{ind} = ilB$  to the left). This induced force opposes the applied force on the bar.
6. End result  $\rightarrow$  the induced force will be equal and opposite to the applied force, and the bar will move at a higher speed than before. The linear machine now is converting mechanical power  $F_{ind} v$  to electrical power  $e_{ind} i \rightarrow$  GENERATOR
7. The amount of power converted :  $P_{conv} = \tau_{ind} \omega$

#### NOTE:

- The same machine acts as both motor and generator. The only difference is whether the externally applied force is in the direction of motion (generator) or opposite to the direction of motion (motor).
- Electrically,  $e_{ind} > V_B \rightarrow$  generator
- $e_{ind} < V_B \rightarrow$  motor
- whether the machine is a motor or a generator, both induced force (motor action) or induced voltage (generator action) is present at all times.
- Both actions are present, and it is only the **relative directions** of the **external forces with respect to the direction of motion** that determine whether the overall machine behaves as a motor or as a generator.
- The machine was a generator when it moved rapidly and a motor when it moved more slowly. But, whether it was a motor or a generator, it always moved in the same direction.
- There is a merely a small change in operating speed and a reversal of current flow.

Starting problems with the Linear Machine

1. Look at the figure here:

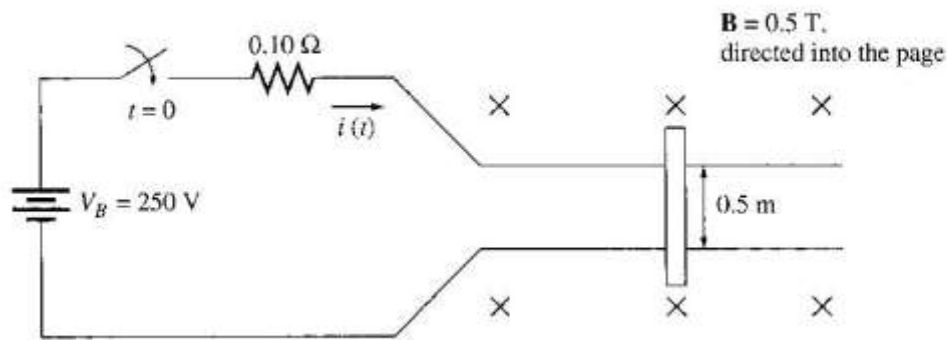

2. This machine is supplied by a 250V dc source and internal resistance  $R$  is 0.1 ohm.
3. At starting, the speed of the bar is zero,  $e_{\text{ind}} = 0$ . The current flow at start is:

$$i_{\text{start}} = \frac{V_B}{R} = \frac{250}{0.1} = 2500\text{ A}$$

4. This current is very high (10x in excess of the rated current).
5. How to prevent?  $\rightarrow$  insert an extra resistance into the circuit during starting to limit current flow until  $e_{\text{ind}}$  builds up enough to limit it, as shown here:

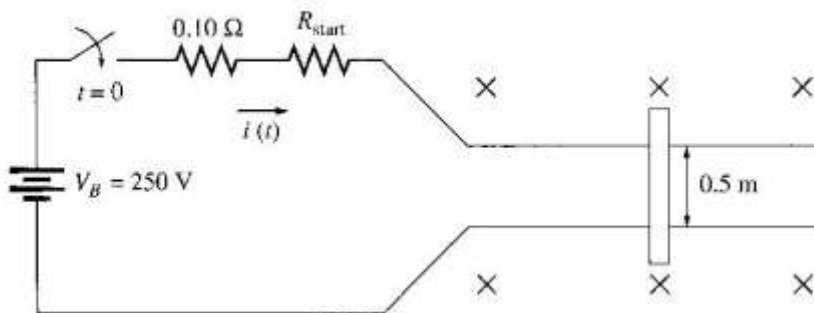

Example 1.10

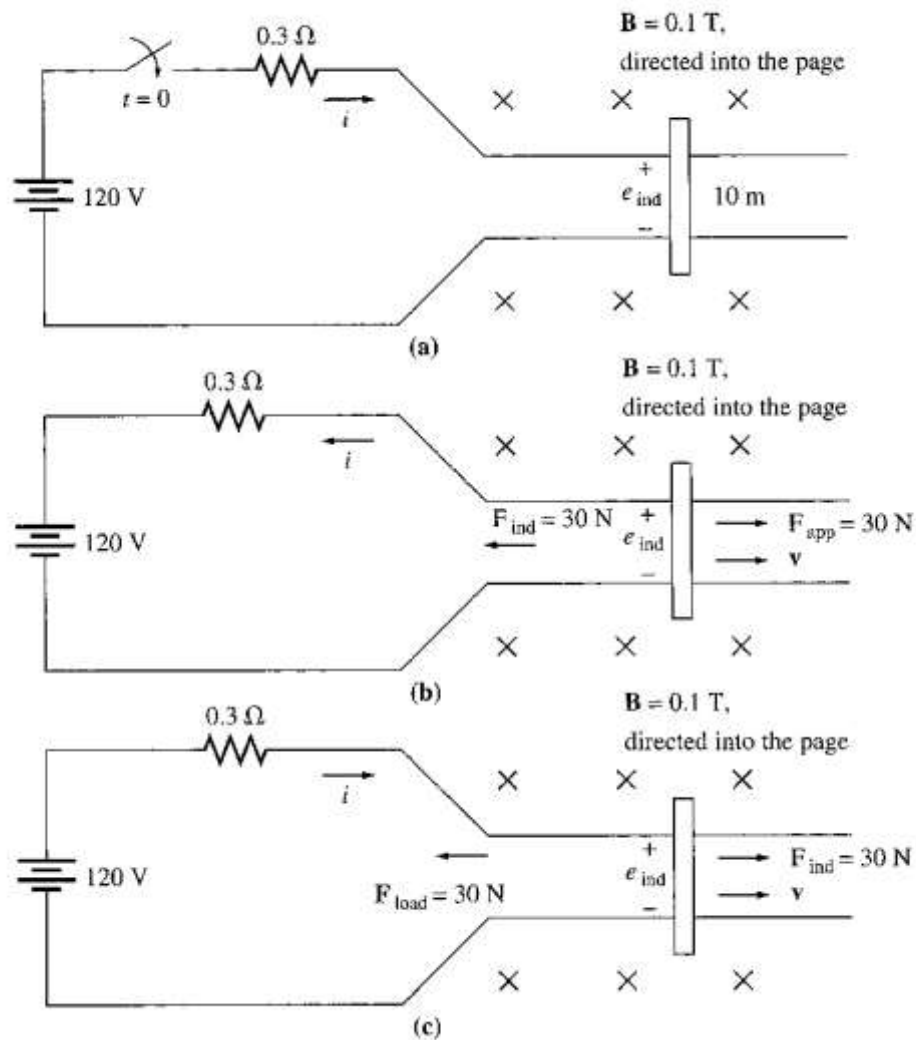

The linear dc machine is as shown in (a).

- What is the machine's maximum starting current? What is the steady state velocity at no load?
- Suppose a 30N force pointing to the right were applied to the bar (figure b). What would the steady-state speed be? How much power would the bar be producing or consuming? How much power would the bar be producing or consuming? Is the machine acting as a motor or a generator?
- Now suppose a 30N force pointing to the left were applied to the bar (figure c). What would the new steady-state speed be? Is the machine a motor or generator now?